

# hoyer

barcelona lights



Press-book  
EUROLUCE  
APRIL 2017

# About BOVER

Passionate about design and craftsmanship, BOVER products are a tribute to the Mediterranean light and lifestyle.

After 20 years of experience in the market, BOVER has today its own subsidiary in the United States and is present in 60 countries worldwide.

Bover has maintained the quest for its original vision: a commercial line that knows how to keep the balance between quality and form.

Bover is produced entirely in Barcelona, exercising full control over its production chain and as a result is able to ensure excellent quality and delivery to meet market needs.

The clean lines, the warm light and the flexibility of finishes presented in our products has positioned Bover as a timeless offering.

"Those of us who live near the Mediterranean know all of light's nuances. Therefore when night arrives we transform it into small spaces of day" (Lluís Porqueras).

*Designers: Joana Bover / Christophe Mathieu / Alex Fernández Camps / Gonzalo Milà / Juan Carlos Ines / Òscar & Sergi Devesa / Luís Porqueras / Jorge Pensi Design Studio / Benedetta Tagliabue· EMBT / Rubén Saldaña*

<https://www.bover.es/>

@BoverBarcelona





hoyer  
barcelona lights



# hover

barcelona lights

OUTDOOR

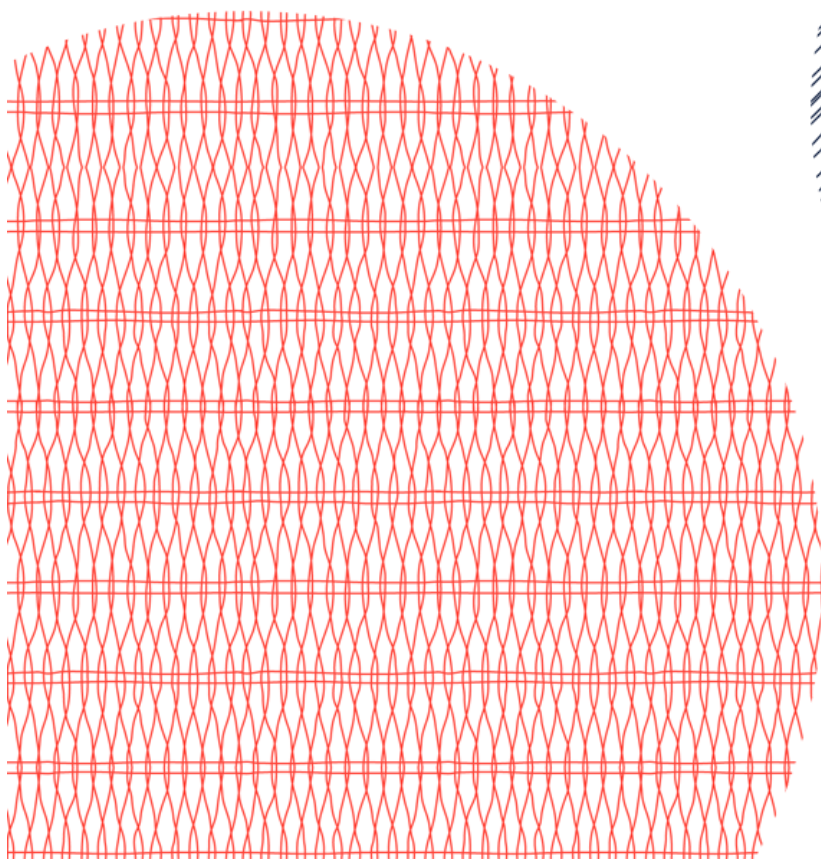

# Outdoor Collection

Maybe because we are from the seaside, Outdoor is one of the fields where Bover is most well-known. The common thread of our outdoor collections is that we offer warm and clear light surrounded by organic and delicate shapes.

Thanks to their highly decorative look, the Outdoor collections can equally be placed both in exterior and interior environments to create a surrounding comfort.

In addition to design, their strong durability make them perfect also for commercial spaces. Their versatility is remarkable making these products unique in exterior solutions.

# Moai

by Gonzalo Milà, 2017

The concept behind Moai was brewing between flights and waiting at airports. Earlier, Gonzalo was left with a comment by Joana Bover: "How can it be that most of bollards are made of aluminium profiles? I don't like what I see". "OK, then let's do something", Gonzalo added quickly.

Just as much a bet for Gonzalo as it was for Bover, Moai was the first beacon lamp that the two of them produced. A new way to go together, and always determined to do something different.

Moai is made from reinforced concrete, allowing you to place it perfectly both in residential or public spaces or other projects. But his creativity lies not so much in the choice of material, but rather in the form that Gonzalo gives it and how the light plays with and penetrates that form. From behind, the beacon lamp shows straight and hard, while front lines are softened. Working his design on concrete allowed him to do something totally new: modeling it exactly as he had it in his mind.

Moai comes with a dimmable LED source that projects light downward. An optic has been added to the LED that does the functions of a magnifying glass; generating in turn a laterally projecting cone of light. And there is the interesting surprise: all of Moai's concavity appears illuminated without leaving any corner in the dark. "The external beacons illuminate the ground or itself but without playing with the shape", explains Gonzalo. "We have managed to get the lamp to illuminate itself completely through its play of shapes". The result is a soft, warm light in contrast to the concrete.

Moai is an outdoor lamp where concrete, shape and light work together to give absolute prominence to this surprising and novel union.



Moai, by Gonzalo Milà

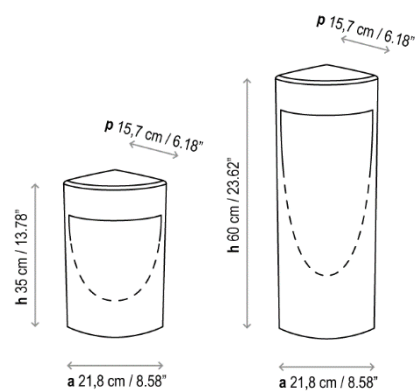



# Atticus

by Joana Bover, 2017

"We must feel good. Wherever we are, really good." This phrase from Joana Bover defines the spirit of her Atticus lamp. A lamp that welcomes and accompanies, making any time and space more attractive. Aesthetics and simplicity, coupled with versatility and functionality.

With Atticus, less is more. Light and simple in its design, yet sophisticated in the possibilities it offers with its discreet personality. "I like lamps that do not intrude," Joana always says. Atticus is always there, creating atmosphere, enveloping, but barely taking up any surface space. A company that follows us wherever we want: next to the table while we eat, by the sofa or in the garden as part of the seasonal design.

The Atticus bollard edition, designed for decorative lighting of private gardens, provides magical warmth to outdoor spaces. These small lamps can be placed under trees or between plants, giving each designer the freedom to create the atmosphere they want.

Both models, bollard and floor lamps, are made of stainless steel pipes and synthetic fiber screen with three color options: brown, beige and off-white. Both also include the same LED light source. Moreover, battery and plug-in versions of the floor lamp are available.

A family of lamps that complements the rest of the Bover outdoor collection, representative of the brand's Mediterranean personality. Joana, founder of Bover, was born in Barcelona to a father from Majorca and is Mediterranean to the core. Blue is part of her DNA. It has seeped into her way of life and expressing herself, thus her taste for light tones, natural and noble materials, and for contemporary pieces that live harmoniously and seamlessly adapt themselves to our way of life. According to Joana, "It boils down to keeping things warm and timeless." That's Bover and that's Atticus.





Atticus, by Joana Bover

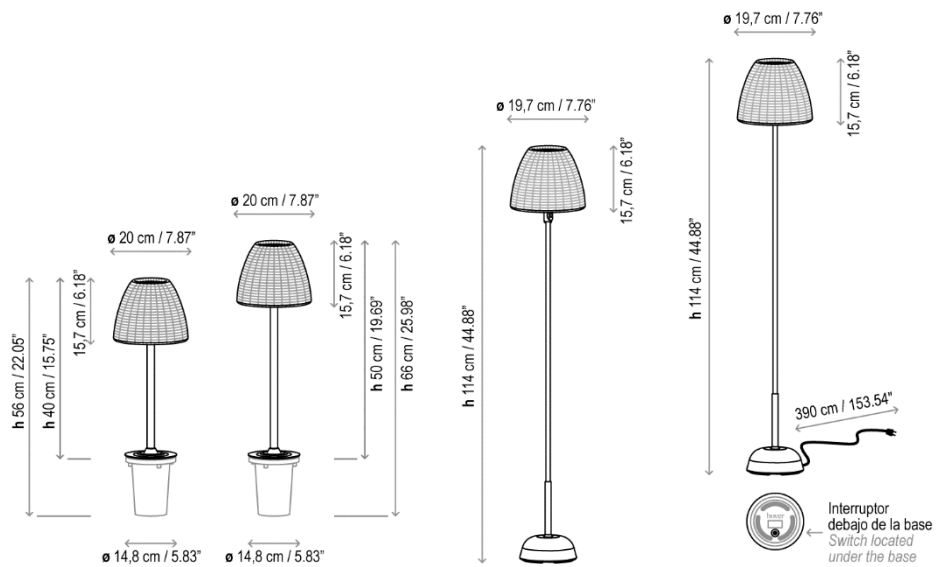



Atticus, by Joana Bover

# Cornet

by Alex Fernández Camps, 2017

Cornet has a personality strongly rooted in nature. A lamp that puts smiles in the faces of those who enjoy it. Its lines are harmonious and organic; it brightens the space it is in and it blends in with nature where there are no straight lines.

It is a lamp made of very high-density polyurethane, which is a very hard and resistant material that is perfect for public spaces. But the Cornet's use is very versatile. It can provide direct lighting like a bollard or more extensive lighting for illuminating larger surfaces. The Cornet lamp family works in the connectivity of spaces; a value that Alex Fernández Camps always upholds. It is mainly used as a bollard lamp but can quickly connect with a wider reality: interior wall lamps, or the post version for intermediate spaces. In all of its designs, Cornet includes a dimmable LED source that distributes light through the lamp's undulating layers, creating an atmosphere that is natural, slightly broken, but never dominant.

Cornet is a highly technical project, but full of life. One of the most interesting moments occurred during the working process when Alex was surprised to discover that the Cornet's lines breathed the organic functionality of Gaudí's buildings, which he had visited as a boy with his father. But the coincidences did not stop there; his full name was Antoni Gaudí i Cornet, and Alex's studio is on Calle Cornet i Más (the engineer who made the metal structures for some of the famous Barcelona markets). An entirely magical crossing of lines involved in the history of this unique Bover lamp made in Barcelona.

In the words of Alex Fernández Camps: "Cornet surprised me during the process, and still amazes me every time I see it. The projects are generous with those who are a part of them, always creating experiences to remember. Especially Cornet."





Cornet, by Alex Fernández Camps

**hover**  
barcelona lights

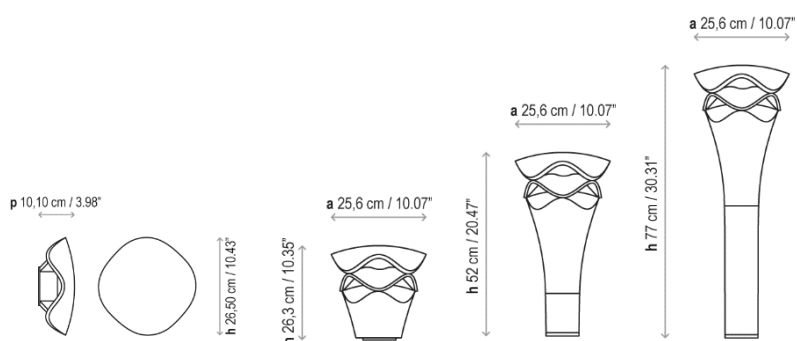





Cornet, by Alex Fernández Camps



Cornet, by Alex Fernández Camps



Cornet, by Alex Fernández Camps



Cornet, by Alex Fernández Camps



# Marietta

by Joana Bover, 2017

Joana Bover had the prototype of the new Marietta Outdoor on her desk sooner than she thought. Joana likes to imagine, draw and quickly hop into the workshop to test and experiment. Before long, she had a very basic model from which she continued to work until she got exactly what she wanted. "Tenacity in design is very important; it's about turning a dream into reality and can't be rushed. Like haute cuisine, when designing a lamp, one has to let things simmer," explains Joana. This is how she made Marietta Outdoor.

Joana created the first Marietta two years ago, a very personal interpretation of the classic industrial suspended lamps that lit most factories in Europe in the early twentieth century. The Marietta lamp is contemporary, decorative, warm, and enveloping. The original Marietta is clearly an indoor light but Joana wanted to adapt it for outdoor settings. To do so, the Outdoor version is made from white polyethylene, with which she imitated the texture and wave-like form of the ribbon-shade in the original design.

It is a lamp designed for terraces, parasols and pergolas; and also for kitchens, bars and restaurants. It is a perfect all-rounder for all these spaces: resistant, easy to clean and very versatile. This versatility has to do with the timelessness that Joana is always looking for in her designs. Her works can stand next to classical pieces and with contemporary ones. This ensures they can be incorporated naturally into people's lives.

The Marietta Outdoor is, for many reasons, an example of 'slow-cooked' design where non-conformity and Joana's conviction play important roles in creating the best possible final product. "Every little detail of Marietta Outdoor was thought about a thousand times. Bover takes this precise approach with every lamp they design. This is what separates many products from others. The quality lies not only in the materials but also in the industrial development behind them", explains Joana. This is why Marietta Outdoor is the best Marietta we have been able to develop.

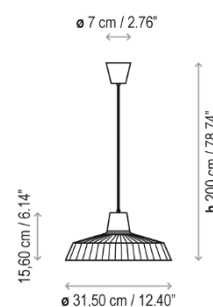



Marietta, by Joana Bover



# hover

barcelona lights

CONTEMPORARY

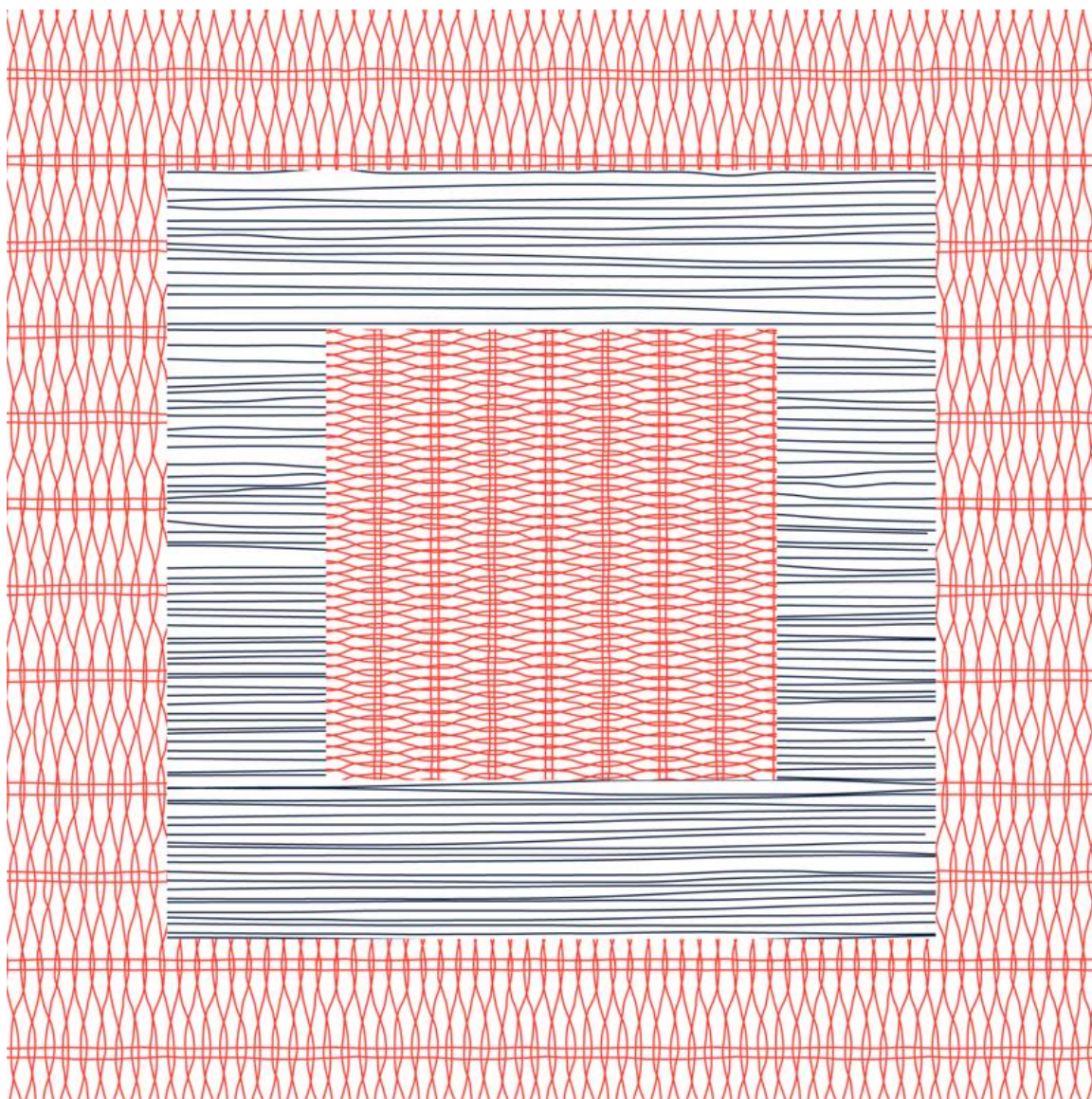

# Contemporary Collection

In Bover we believe that the right combination between design and technical development is crucial for a successful product.

We like to say that we create “heart made contemporary design lighting pieces”. Heart made because we are careful about details and contemporary because our products will remain actual in the future.

The contemporary collection is the result of the professionalism and the concerns of a team of people who live and feel the cultural world surrounding them, of a team of respected designers advocating the creation of new lighting experiences for the whole world.



# Penta

by Gonzalo Milà / Juan Carlos Ines, 2017

Penta is the story of a first dream come true. Twenty years ago, in 1996, Gonzalo Milà and Juan Carlos Ines designed a lamp made of aluminium. The result was a piece with aluminium sheets folded and joined by their corners. But at that time his idea was a prototype. Even today, this first lamp illuminates Gonzalo's dining room from its simplicity.

"We were very fond of this project and we were determined to push it forward," explains Gonzalo. The moment to launch Penta finally arrived, and a very important change to make it happen was to replace the initial folded plate with the stamping technique.

Three finishes have been chosen for Penta: brass, aluminum and copper; respecting the lamp's interior color and applying an oxidation process to the outside of the lamp. The contrast between the dark tone of the outside and the brightness of the colors of each material inside gives Penta a very sophisticated image, perfect for illuminating the most special spaces.

According to Gonzalo and Juan Carlos: "The premise was to make an interior table lamp in which you could have a lightened surface that doesn't dazzle. We wanted to have conversations around a table looking at the faces of the people that you're talking to." Choose a corner and let Penta create its warm atmosphere, either illuminating a space or as mood lighting thanks to the incorporated dimmer. And although its light source focuses downwards, the installation of a diffuser allows the light to also be distributed sideways. More red, more yellow, or white, depending on the finishes. With all these features, Penta not only easily finds its place in the home but also perfectly adapts to the environment of a hotel or to any type of project within the Contract industry.

The current Penta, is the result of two moments in time, 1996 and 2016, united by the illusion of Gonzalo, Juan Carlos and Bover.



Penta by Gonzalo Milà / Juan Carlos Ines



Penta by Gonzalo Milà / Juan Carlos Ines

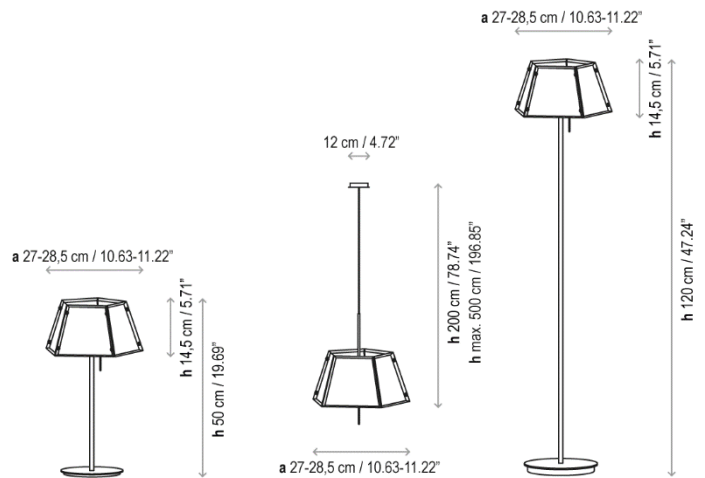



# Drop

by Christophe Mathieu, 2017

The Drop is born of conversations and reflections, of drawings on terraces of restaurants and of being carried away by the idea that "one thing leads to another". That's how a design with more than ten references is reached that satisfies both residential and contract sector needs. A family of lamps that speak the same language but in which each one has its own personality.

With the Drop, the goal was clear from the beginning: make a cascade pendant lamp. One of the most outstanding features of the Drop is its diversity of sizes. We find versions of 1, 6, 7, 12, 24, 36 and 48 lights only in suspension. The biggest has a diameter of 1 meter, which gives it a great visual impact. Any of them, although they are drawn from standard measures, can be customized at the request of the client. And so, starting from this initial premise, ideas of new typologies began to emerge: several wall lamps, two table lamps, a floor version with a support tray and USB connection, and also a specific solution for libraries.

Drop's small screen is made of borosilicate glass, finer and more delicate than blown glass. "I wanted the material to be very tasteful, almost like a candy," says Christophe. The choice of glass is intimately related to the light that creates the Drop. In the words of its creator: "I was looking for a very bright light, and the translucent glass and its shape contribute to it. The light source is an LED that is hidden so that light is the only protagonist. Then, when the light is projected and reflected in the materials that are found along the way, it creates a set of sparkles and shadows. All that, enrich the object. " Its light is intimate, but it also has a practical utility for those who are nearby. "I always bear in mind the space where a lamp is going to be located because that is where it becomes meaningful" explains Christophe. The Drop is intended for application in both residential and contract projects. Thanks to its multiple applications it works very well in all hotel spaces, in public areas as well as in rooms.

The relationship with the Drop, as Christophe says, goes *in crescendo*. First, it seduces you from a distance, enough for you to want to get closer to it. Once you are by its side you like its design, and that motivates you to take the last step and turn it on. Then, the magic reaches its maximum splendor.





Drop, by Christophe Mathieu



Drop, by Christophe Mathieu



Drop, by Christophe Mathieu



Drop, by Christophe Mathieu





Drop Biblio, by Christophe Mathieu

# PENDANTS

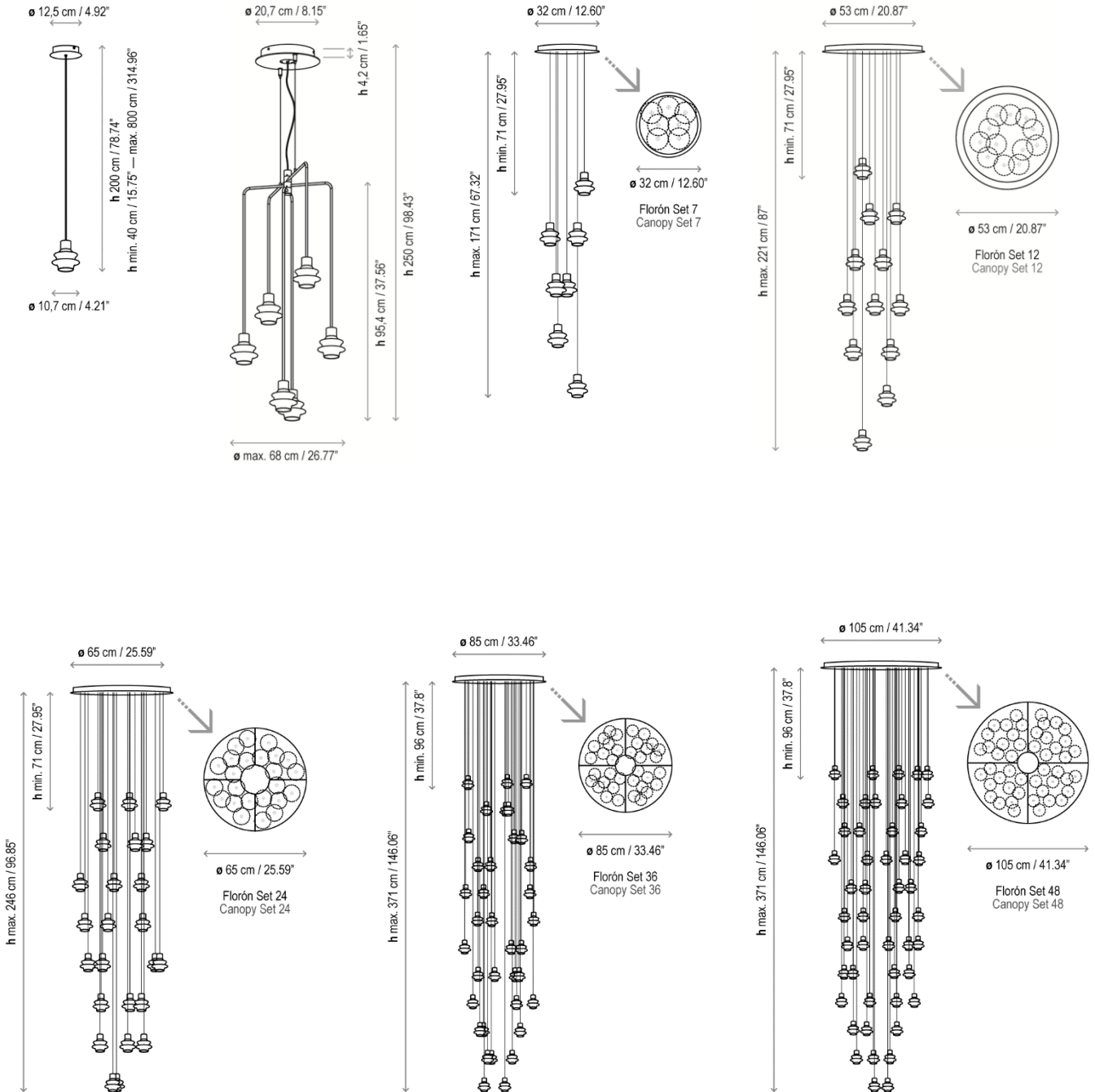

# Wall

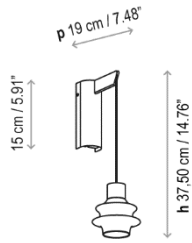
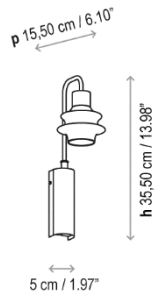
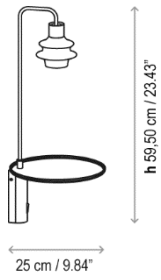

# Library

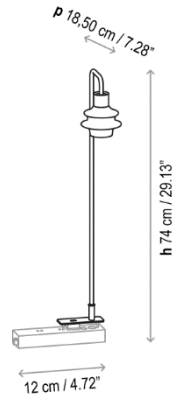

# Table

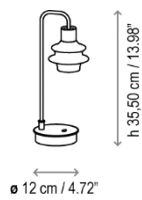
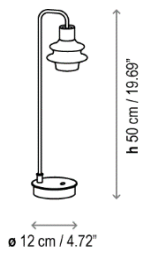

# Floor

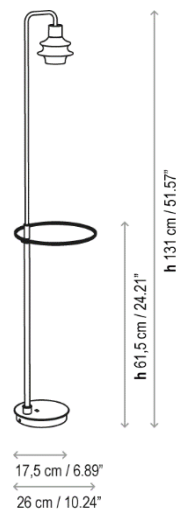



# Drip

by Christophe Mathieu, 2017

Drip takes the diversification of the Drop to its maximum expression. A lighting system that not only evolves in multiple product types, but also in another concept of lampshades.

The new lampshade is Drip's alma mater: simple, minimalist and with straight lines. When we change the lampshade, we have the sensation that it is a completely new lamp.

The Drip's small lampshade is also made of borosilicate glass, fine and delicate. The choice of glass is intimately related to the light it creates, a brilliant and intimate light, that also has a practical use for those nearby. "I always bear in mind the space where a lamp is going to be located because that is where it becomes meaningful," explains Christophe. The Drip has been created for residential as well as contract projects. Thanks to its multiple applications it works very well in all hotel spaces, in public areas as well as in rooms.

Drip has the Drop structure, but a unique 100% Drip personality.



Drop, by Christophe Mathieu



Drop, by Christophe Mathieu





Drop, by Christophe Mathieu

# PENDANTS

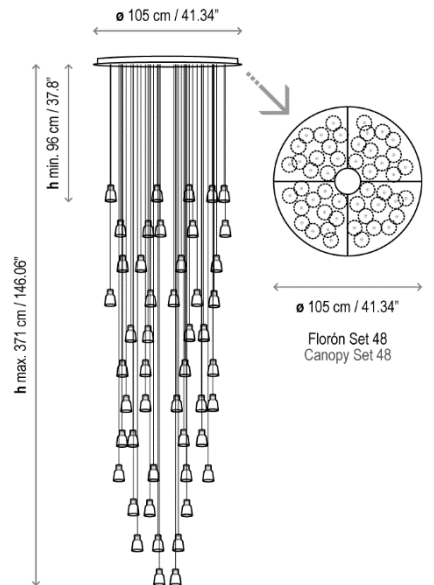
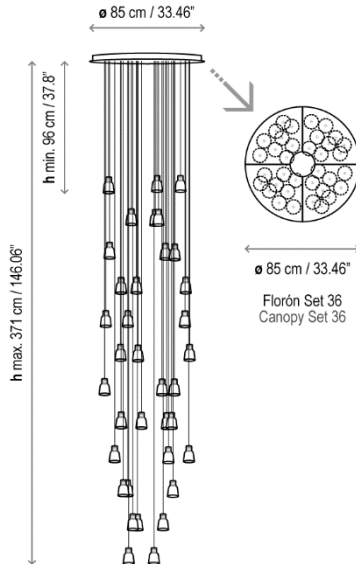
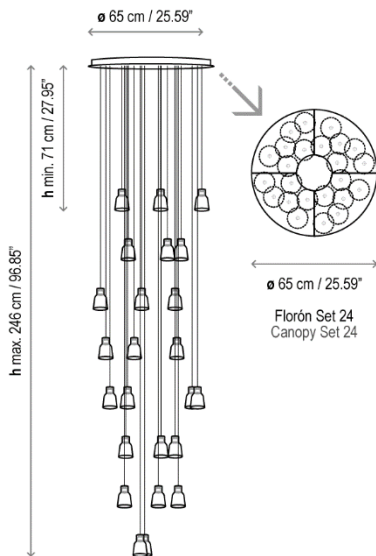
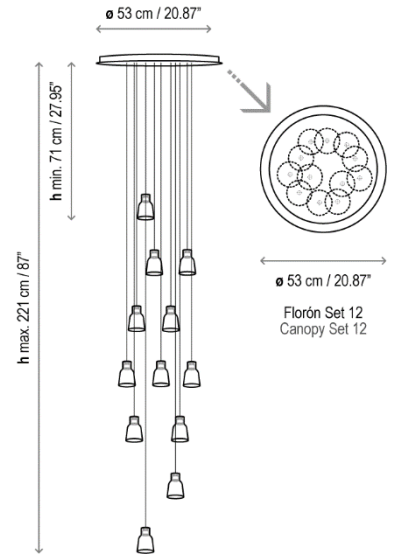
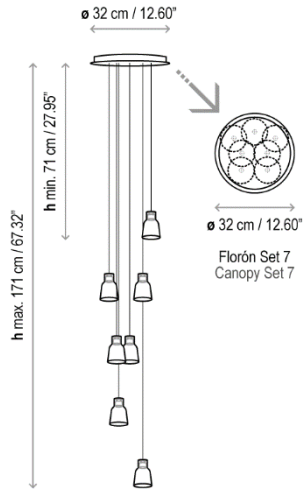
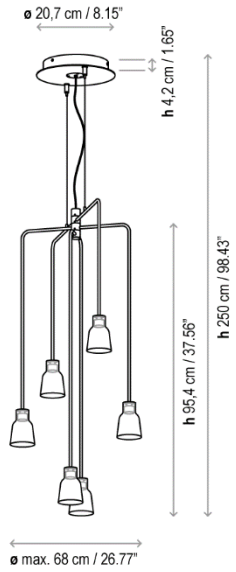
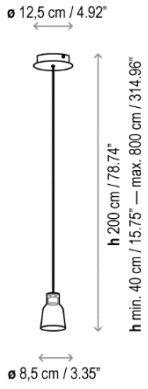

# Wall

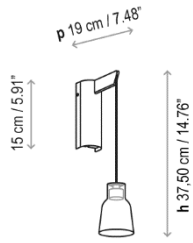
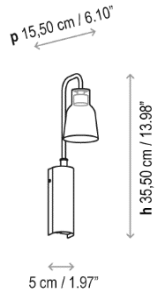
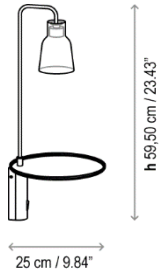

# Library

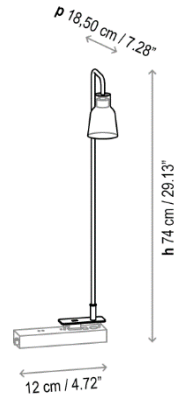

# Table

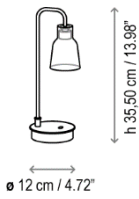
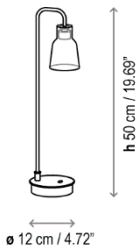

# Floor

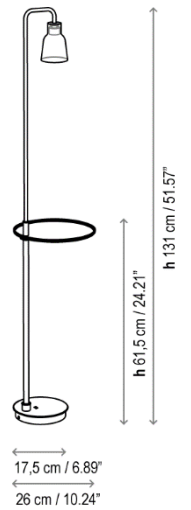



# Tibeta

by Christophe Mathieu, 2015

TIBETA is a family of pendant lights made of a spun aluminum body.

It is available in three different sizes and shapes which can be used either individually or in groups of three or more units according to client's needs.

Tibeta includes a led module inside, which provides direct bottom light.

On this occasion we are presenting a new finishing; Antique Brass, a neutral and elegant color that perfectly complete the collection available also in black chrome and copper.

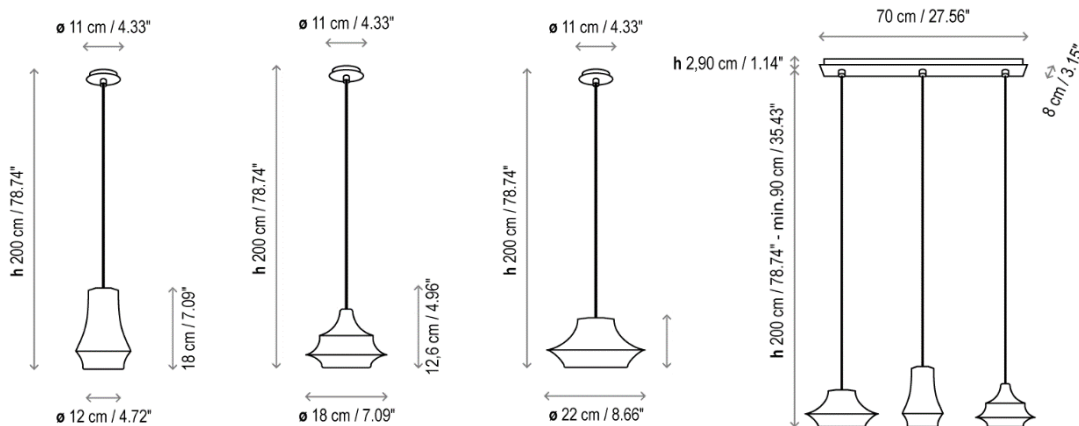



Tibeta, by Christophe Mathieu



Tibeta, by Christophe Mathieu

**hover**  
barcelona lights

---

Avda. Catalunya 173  
Poligon Ind. Sud  
08440 Cardedeu  
Barcelona, Spain

T. +34 938 713 152  
F. +34 938 462 089  
info@bover.es  
www.bover.es

1231 Collier Road,  
Suite C  
Atlanta, GA 30318  
United States

T. +1 (404) 924 2342  
info@boverusa.com  
www.boverusa.com