

DRACO

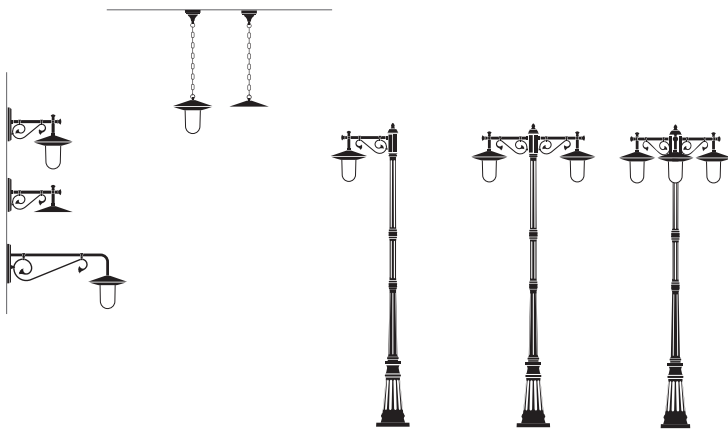

2351

ACCESSORI OPZIONALI OPTIONAL ACCESSORIES - ACCESSOIRES EN OPTION

**6047-A-1**

Prolunga per palo
(2351-28/29/31)
Pole extension - Rallonge pour poteau

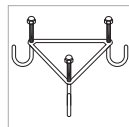
**9974-A**

Fissaggio a terra per pali
Ground fixing for poles
Fixation au sol pour poteaux
per base-for base-pour base 260x230 mm

Vedi pagina 20 per ulteriori informazioni
See page 20 for more information - Voir page 20 pour plus d'informations

COLORI STANDARD STANDARD COLOURS - COULEURS CLASSIQUES

00	01	10	24	25	30	35	40
BIANCO PURO RAL 9016 PURE WHITE BLANC PUR	NERO RAL 9005 BLACK NOIR	BIANCO RAL 9010 WHITE BLANC	BRONZO BRONZE BRONZE	RUGGINE RUST ROUILLE	ANTRACITE ANTHRACITE ANTHRACITE	ARDESIA SLATE ARDOISE	GRIGIO RAL 9006 GREY GRIS

COLORI SPECIALI SPECIAL COLOURS - COULEURS SPÉCIALES

02	03	04	05
NERO-ORO BLACK-GOLD NOIR-DORE	NERO-RAME BLACK-COPPER NOIR-CUIVRE	NERO-VERDE BLACK-GREEN NOIR-VERT	NERO-GRIGIO BLACK-GRY NOIR-GRIS

CARATTERISTICHE

Realizzato con materiali di elevata qualità, Draco è un prodotto ideale per l'utilizzo in esterno. L'eleganza delle sue forme e la possibilità di installazione a parete ed a terra lo rendono estremamente versatile ed adattabile ad ogni esigenza di ambientazione. Il diffusore in policarbonato opale garantisce una propagazione della luce sempre omogenea ed ottimale. Draco è un connubio perfetto tra armonia delle forme e solidità di struttura e vi garantirà stile ed affidabilità nel tempo.

Installazione:

a parete, a terra

Componenti:

pressofusione di alluminio EN AB 46100, verniciato con polveri poliesteri ad elevata resistenza ai raggi UV e alla corrosione

Diffusori:

policarbonato opale

policarbonato trasparente (opzionale)

Portalamпада:

E27

Lampada non inclusa

Cablaggio:

tensione di rete 220-240V

Viterie:

acciaio inox

Guarnizione:

silicone espanso - silicone stampato

Isolamento:

Classe I

Normative:

conformità alle norme EN60598-1

Marchio:

CE

Accessori opzionali:

Triangolo per il fissaggio al terreno

5014-A (per base 260x230 mm)

Tirante zincato per il fissaggio al terreno

3 x 5020-A

Bullone INOX per il fissaggio al terreno

3 x 5021-A

FEATURES

Made with high quality materials, Draco is an ideal product for outdoor use. The elegant designs and possibility of wall and floor mount installation make it extremely versatile and adaptable to every setting requirement. The opal polycarbonate diffuser guarantees a constantly uniform and optimal distribution of light. Draco is a perfect union of harmonious design and a solid structure to guarantee style and reliability over time.

Fixing:

wall fixing, ground fixing

Components:

die cast aluminium EN AB 46100 painted with polyester powder UV ray and corrosion resistant

Diffusori:

policarbonato opale

policarbonato trasparente (opzionale)

Lampholder:

E27

Lamp not included

Wiring:

voltage 220-240V

Screws kit:

stainless steel

Gasket:

expanded silicone - moulded silicone

Insulation:

Class I

Norms:

manufactured in compliance with EN60598-1 norms

Mark:

CE

Optional Accessories:

Triangle for ground fixing

5014-A (for 260x230 mm base)

Zinc-plated tie-rod for ground fixing 3 x 5020-A

INOX screw bolt for ground fixing 3 x 5021-A

CARACTÉRISTIQUES

Réalisé avec des matériaux de grande qualité, Draco est un produit parfait pour une utilisation en extérieur. L'élégance de ses formes et la possibilité d'installation au mur et au sol le rendent extrêmement versatile et lui permettent de s'adapter à tout dé-cor ou agencement. Le diffuseur en polycarbonate opale garantit une propagation de la lumière toujours homogène et optimale. Draco est l'union parfaite entre harmonie des formes et solidité de la structure et il garantit style et fiabilité au fil du temps.

Installation:

au mur, au sol

Composants:

aluminium moulé sous pression EN AB 46100, peint avec poudres polyester ayant une haute résistance aux rayons UV et à la corrosion

Diffuseurs:

polycarbonate opale

polycarbonate transparent (en option)

Douille de lampe:

E27

Ampoule non incluse

Câblage:

tension de réseau 220-240V

Visserie:

acier inox

Garniture:

silicone expansif - silicone moulé

Isolement:

Classe I

Réglementations:

Conformité avec les normes EN60598-1

Marquage:

CE

Accessoires en option:

Triangle pour la fixation au sol

5014-A (pour base 260x230 mm)

Tirant galvanisé pour fixation au sol 3 x 5020-A

Boulon INOX pour la fixation au sol 3 x 5021-A

22-23 2351



2351-22



2351-23



COD.	LAMP	V	W
2351-22...30 2351-23...30	E27	250	75 max

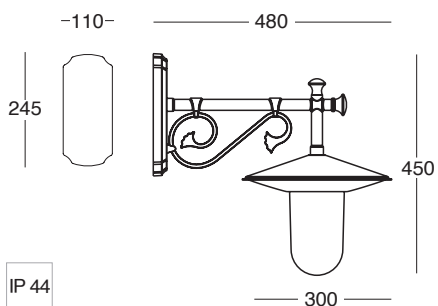

IP 44

2351-22

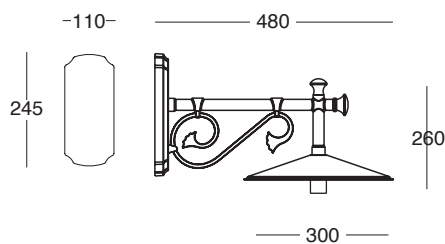

IP 20

2351-23

21 2351



COD.	LAMP	V	W
2351-21...30	E27	250	75 max

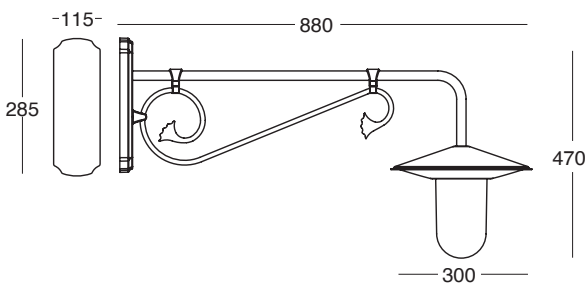

2351-21

01-20 2351



2351-01



2351-20



COD.	LAMP	V	W
2351-01...30 2351-20...30	E27	250	75 max

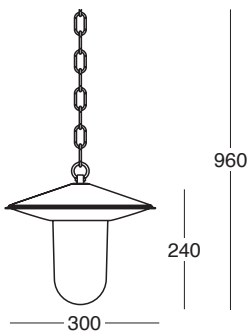

IP 44

2351-01

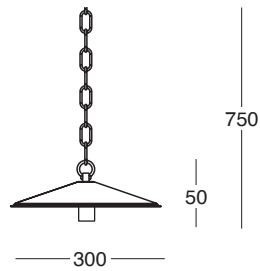

IP 20

2351-20

28-29-31 2351

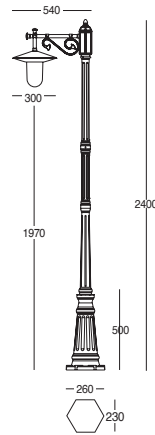

2351-28 * KIT 9974-A

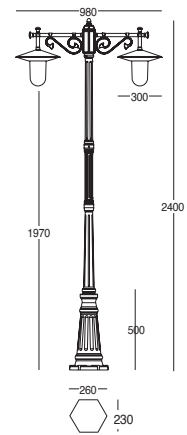

2351-29 * KIT 9974-A

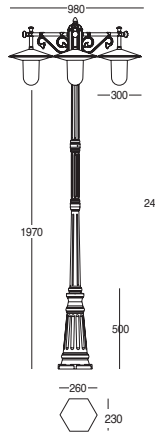

2351-31 * KIT 9974-A

* FISSAGGIO A TERRA PER PALI (OPZIONALI)
GROUND FIXING FOR POLES (OPTIONAL)
FIXATION AU SOL POUR POTEAUX (EN OPTION)

per base-for base-pour base
260x230 mm

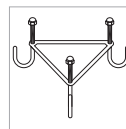

9974-A



COD.	LAMP	V	W
2351-28...30			
2351-29...30	E27	250	75 max
2351-31...30			